

Measurement of NPK, Temperature, Moisture, Humidity using WSN

¹Mr. Gaikwad S.V, ²Prof. Galande S. G.

M.E ETC (VLSI & Embedded sys.)

Associate Professor, PRECLoni PREC, Loni

ABSTRACT

In India, where the economy is mainly based on agriculture and the climatic conditions are isotropic and are not able to make full use of agricultural resources. The main reason is the lack of rains and scarcity of land reservoir water and overuse of fertilizers so we need to control these parameters. This system made wireless sensor network for monitoring agricultural environments for various factors such as NPK, temperature and humidity along with other factors can be of significance. By using pH sensors we get the information about the soil and analyze the acid level of the soil. By which we can apply fertilizer to the place where it needs, also we can avoid over fertilization of the crops. We used humidity sensor to sense the weather. By this the farmer can get idea about the climate. If there is any chance for rainfall; the farmer need not irrigate the crop field. This Seminar reports the design and development of a smart wireless sensor network (WSN) for an agricultural environment. Monitoring agricultural environments for various factors such as Nitrates, Zinc, Potassium, Phosphorus, Humidity and Temperature along with other factors can be of significance. The ability to document and detail changes in parameters of interest has become increasingly valuable. Investigations were performed for a remote monitoring system using WiFi, where the wireless sensor nodes are based on WSN802G modules. These nodes send data wirelessly to a central server, which collects the data, stores it and allows it to be analyzed and displayed as needed.

Keywords: X-bee Module; LPC2131/2132/2138 ARM7 temperature measurement; humidity measurement, NPK measurement; soil moisture; water level; light detection;

I. INTRODUCTION

In India, where the economy is mainly based on agriculture and the climatic conditions are isotropic and are not able to make full use of agricultural resources.

When generating the idea for this project, the likely scenario considered was deployment in agricultural environments such as fields or greenhouses. The wireless sensor network investigates being a comparatively self-organizing system. It allows sensor nodes to connect to a network and have their data logged to a selected server. Sensor Networks provide wide variety of applications and awareness has increased with regards to implementing technology into an agricultural environment. Manual collection of data for chosen factors can be sporadic and produce variations from incorrect measurement taking; this can cause complications in controlling any important factors. Wireless sensor nodes can reduce effort and time required for monitoring a particular environment. The logging of data allows for reduced likelihood of data being misplaced or lost. Sensor nodes could be placed in critical sites without the need to put personnel in hazardous situations. The utilization of technology would allow for remote measurement of factors such as temperature,

humidity, moisture and NPK. There seems to be increased development aimed towards wireless solutions in comparison to wired-based systems. One particular reason is sensor location can often require repositioning and traditional wire layouts could cost a significant deal of energy and time. The system aims to reduce the cost and effort of incorporating wiring and also to enhance the flexibility and mobility of sensing points.

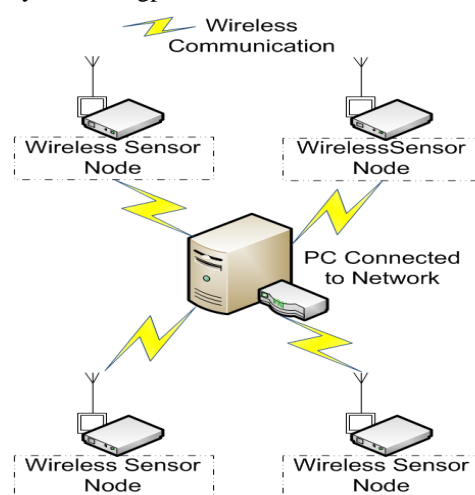

Figure 1.1. Concept of Wireless Monitoring of Agricultural Environment.

A system has been developed which can monitor environmental factors of interest, where data can be sent or received and, an operator who is based at a remote location can issue commands using a wireless medium. The conceptual diagram is shown in (Figure1.1). This seminar describes the development of a wireless sensor network for measuring environmental factors. The wireless connection is implemented to acquire data from the various sensors, in addition to allow set up difficulty to be reduced.

A: SYSTEM CONFIGURATION: Various sensors are used for monitoring the environmental factors as well as the soil parameters. The outputs of various sensors are connected to the WSN via multiplexer. At user defined intervals the signals are measured, transferred and logged to the server on the network. The server can be connected to the network via a standard Wireless-G router .Arm processor operated on the battery. Central control unit receives the data from the WSN via RF transceivers and compares with the programmed data in the PC

II. HARDWARE DISCRPTION

A: Functional Block Diagram: The system being developed is based on the WSN802G Wi-Fi / 802.11 modules in order to communicate data to a selected Server (Figure2.1).

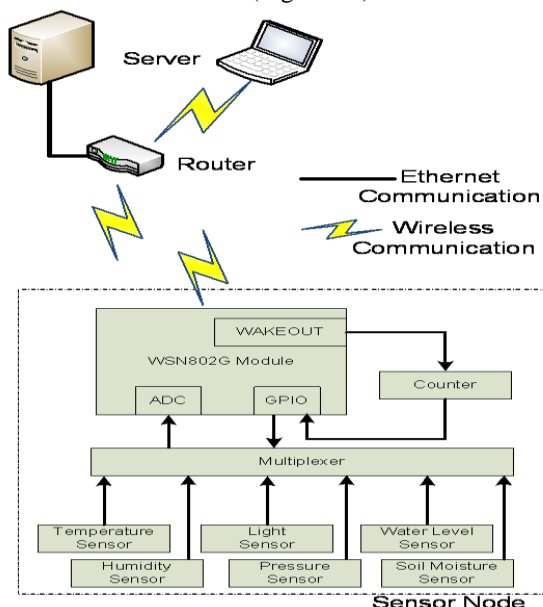

Figure 2.1: Functional Block diagram of System being developed.

The WSN802G module is connected to the various sensors like temperature, light, humidity, moisture and NPK sensors with analogue outputs via a multiplexer used for signal gating. The multiplexer channels can be selected based on the counter output to the General Purpose Input/output (GPIO) on the

WSN module or entirely based on GPIO output values. At user defined intervals the signals are measured, transferred and logged to the server on the network. The server can be connected to the network via a standard Wireless-G router, either wireless itself, or through a wired Ethernet connection. This allows for portability so the server can be run on a Wi-Fi enabled laptop in the field. The WSN802G module is compatible with standard 802.11b/g/n routers. The WSN802G module is able to go into sleep while still remaining part of an 802.11b/g/n network. This technique allows for energy saving suited for battery operation. The sensor nodes can be used with routers that are serving other applications and it is possible to have applications running on a server or PC, communicating with one or more WSN802G sensor nodes.

B: System Block Diagram:-It is proposed to implement a WSN system based Wi-Fi, which consist of ARM9/ARM11 and WSN comprising of different sensors. It is proposed to sense, temperature, moisture, humidity atmosphere and nitrates, potassium and phosphorus (NPK) in the soil and control it with wireless communication.

a: Wireless sensor node:-A wireless sensor network (WSN) is an infrastructure comprised of sensing, computing and communication elements that allows the administrator to monitor & control of the specified parameters in the network. Typical application of WSN includes data collection, monitoring, surveillance & medical telemedicine. It is also used in irrigation system, Greenhouses for monitoring & controlling parameters like water flow, temp, humidity, moisture, etc.

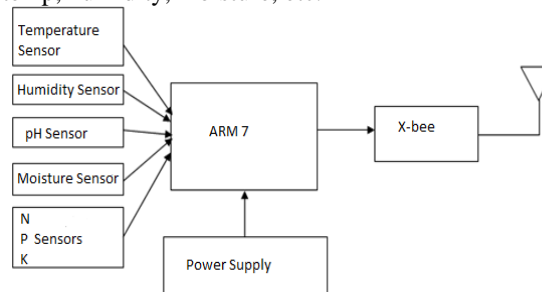

Figure 2.2. wireless sensor node

A wireless sensor network (WSN) is an infrastructure comprised of sensing, computing and communication elements that allows the administrator to monitor & control of the specified parameters in the network. Typical application of WSN includes data collection, monitoring, surveillance & medical telemedicine. It is also used in irrigation system, Greenhouses for monitoring & controlling parameters like water flow, temp, humidity, moisture, etc.

i) Soil moisture sensor and unit In a row of plantation two wires are used. These wires are covered with the soil. One wire is grounded and another is used to sense the moisture in the soil. When there is sufficient moisture in the soil, the two wires get shorted, hence the base potential of transistor T1 becomes 0V and it forces to cut-off region. This forces transistor T2 to cut-off and the collector potential of transistor T2 becomes +5V. Hence soil moisture is sensed.

The schematic diagram of the moisture measurement circuit is as shown below.

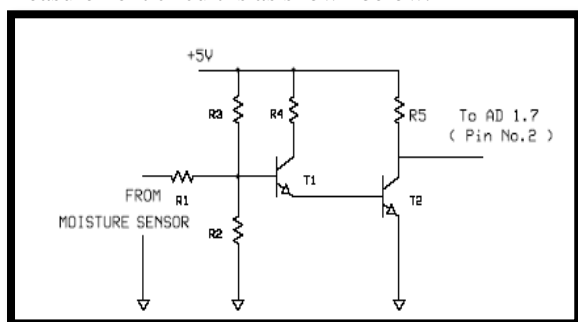

Fig 2.4 Signal Conditioning Circuit for Moisture Measurement

The output of the Moisture is connected to the ARM processor at pin no.13, which is the analog input (AD 0.1) of the ARM processor.

ii) Temperature sensor: The LM35 series are precision integrated-circuit temperature sensors, with an output voltage linearly proportional to the Centigrade temperature. Thus the LM35 has an advantage over linear temperature sensors calibrated in ° Kelvin, as the user is not required to subtract a large constant voltage from the output to obtain convenient centigrade scaling. The low output impedance, linear output, and precise inherent calibration of the LM35 make interfacing to readout or control circuitry especially easy. The device is used with single power supplies, or with plus and minus supplies. The LM35 is rated to operate over a -55°C to +150°C temperature range, while the LM35C is rated for a -40°C to +110°C range

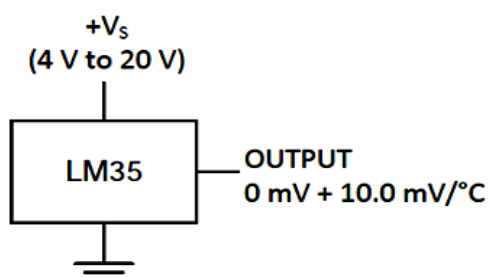

Figure 2.4: Basic Centigrade Temperature Sensor (+2°C to +150°C)

iii) Humidity Sensor Units: Humidity is one of the important parameter of any green house. As there are so many types of humidity sensors, here P-Hs-220 humidity sensor is used. The output of this humidity sensor is proportional to output voltage. At 20% relative humidity, the output is 660 mV, while at 90% relative humidity; the output is 2970 mV, i.e. 2.97 V.

The output of the Humidity is connected to the ARM processor at pin no.35, which is the analog input (AD 1.2) of the ARM processor.

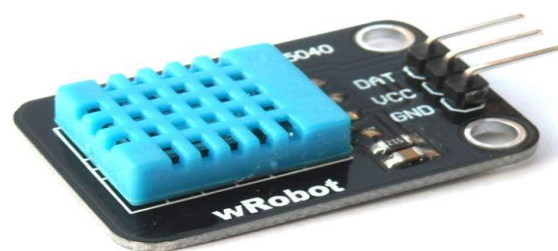

Figure 2.5: Humidity Sensor

iv) NPK Sensor: Another important parameter of any green house is the NPK measurement. Proper contents of the NPK are required for the growth of the crop. The NPK sensors available in the market give the output in terms of milli-volts and there are three different sensors for N, P, and K. The requirement of such measurement is an amplifier with high input impedance and has the gain of voltage-NPK conversion. Nivo-press NPK Probe will used to measure the level of micro parameter from soil. When one metal is brought in contact with another, a voltage difference occurs due to their differences in electron mobility. When a metal is brought in contact with a solution of salts or acids, a similar electric potential is caused, which has led to the invention of batteries. Similarly, an electric potential develops when one liquid is brought in contact with another one, but a membrane is needed to keep such liquids apart.

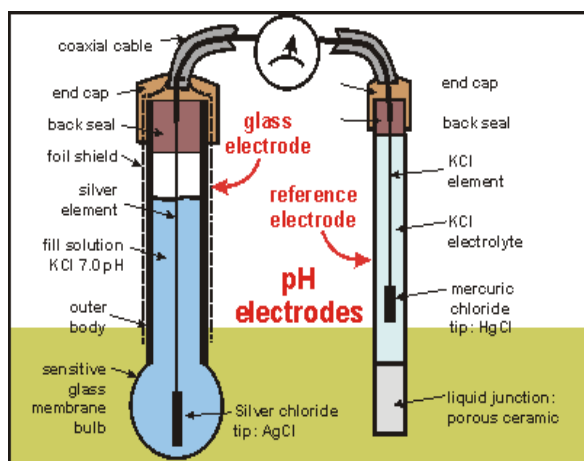

Fig2.6 NPK Sensor

v) PHMeasurement: A pH measurement is actually, a precise voltmeter that measures the generated voltage of a pH electrodes. The requirement of such measurement is an amplifier with high input impedance and has the gain of voltage-pH conversion. The standard pH probe generate voltage about 59mV per pH .So a pre-amplifier is required with high input impedance input and with gain = 16.7 to give 1 Volt per pH. The schematic diagram of the pH measurement circuit is as shown below.

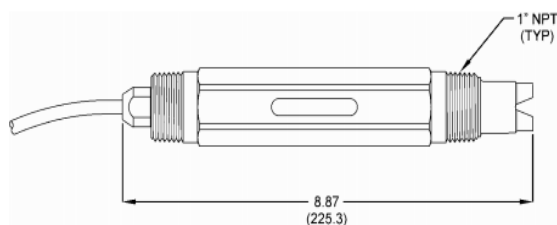

Fig:2.7 pH sensor

vi)Light intensity measurement

For light intensity measurement, LDR is used. LDR is Light Dependent Resistor. As light intensity increases, the resistance decreases, and vice versa. In this project, I have designed a voltage divider network using LDR and a resistance. As the intensity changes, the voltage drop across the LDR also changes, and hence potentials proportional to the light intensity. Amplifier amplifies this change in potential. The signal conditioning circuit is as follows:

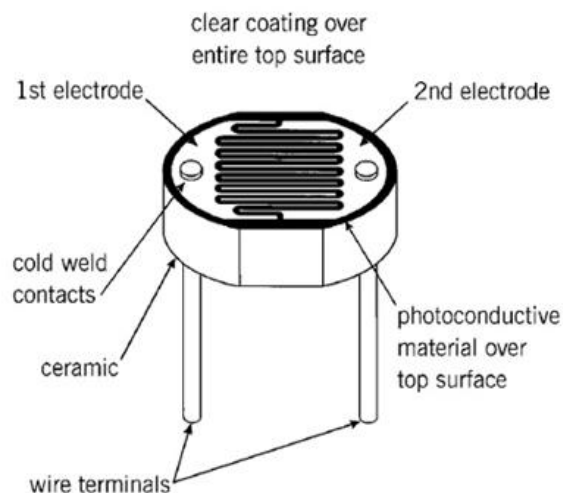

Fig 2.8 LDR Sensor

2) ARM 7:-The LPC2131/2132/2138 microcontrollers are based on a 32/16 bit ARM7TDMI-S™ CPU with real-time emulation and embedded trace support, that combines the microcontroller with 32 kB, 64 kB and 512 kB of embedded high speed Flash memory. A 128-bit wide memory interface and unique accelerator architecture enable 32-bit code execution at maximum clock rate. For critical code size applications, the alternative 16-bit Thumb® Mode reduces code by more than 30 % with minimal performance penalty. Due to their tiny size and low power consumption, these microcontrollers are ideal for applications where miniaturization is a key requirement, such as access control and point-of-sale. With a wide range of serial communications interfaces and on-chip SRAM options of 8/16/32 kB, they are very well suited for communication gateways and protocol converters, soft modems, voice recognition and low end imaging, providing both large buffer size and high processing power.

3)X-Bee Module: The XBee-PRO OEM RF Modules were engineered to meet IEEE 802.15.4 standards and support the unique needs of low-cost, low-power wireless sensor networks. The modules require minimal power and provide reliable delivery of data between devices. The modules operate within the ISM 2.4 GHz frequency band and are pin-for-pin compatible with each other.

b: Base station:-Base station consists of the same RF transceiver and LCD which displays, monitor and controls the signals depending on the programmed data.

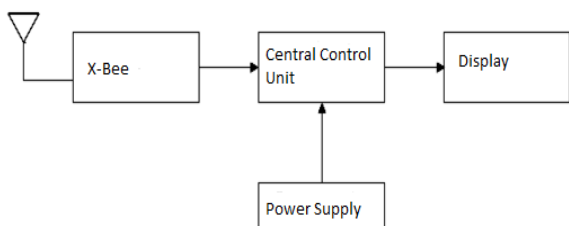

Figure 2.9: Base station

Central control unit:-Central control unit receives the data from the WSN via RF transceivers and compares with the programmed data in the PC; if the data doesn't matches with the standard value of particular application in the PC then it takes the appropriate controlling action.

III. FACTORS OF INTEREST AND SENSOR OUTPUT

The system investigates some essential factors for measurement like: Temperature, Humidity, NPK, Pressure, Water Level, Soil Moisture

Depending on the agricultural product being grown temperature can affect growth, germination, sprouting, flowering and fruit development.

Humidity is of importance, as when levels are too low or high agricultural products can suffer. If humidity is kept below 50 percent for extended periods, growth can suffer as loss of water from leaves can be more rapid than replacement. Similarly, if humidity is above 80 percent for extended periods, risk of disease can increase. Air pressure measurement is a variable of interest, as it is related to other weather factors that might be used for prediction of upcoming changes in the environment. Low pressure is often associated with poor weather, while rapid changes in pressure mean possible radical weather changes.

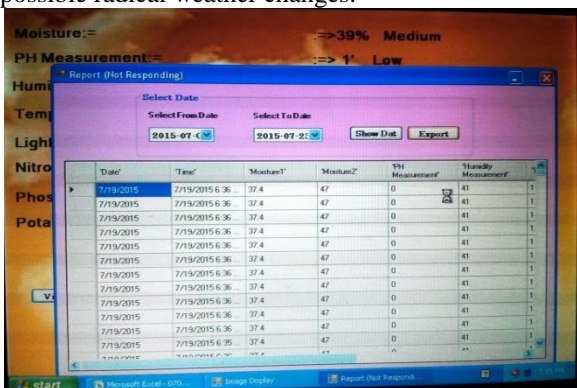

Fig: 3.1 result

IV. SOFTWARE PLATFORM

A: NETWORK TRAFFIC AND DATA STORAGE: The system's commands and responses sent through the network are formatted as UDP/IP packets. The server stores the received data into a comma-separated value (CSV) file format which can

be straightforwardly exported to a database, excel file or other software in order to perform analysis and displaying of data. The system creates a CSV file in the same directory as the logging application being executed. A CSV file with a filename of the current date is created in the form of "DD-MM-YYYY.csv". If a file already exists for that date it will continue adding entries to the existing file. The data logged per I/O Report entry is Timestamp, Source IP Address, Source MAC Address, ADC0 value, ADC1 value, Battery/Supply Voltage, GPIO0 and GPIO1 values and RSSI (Figure 4.1).

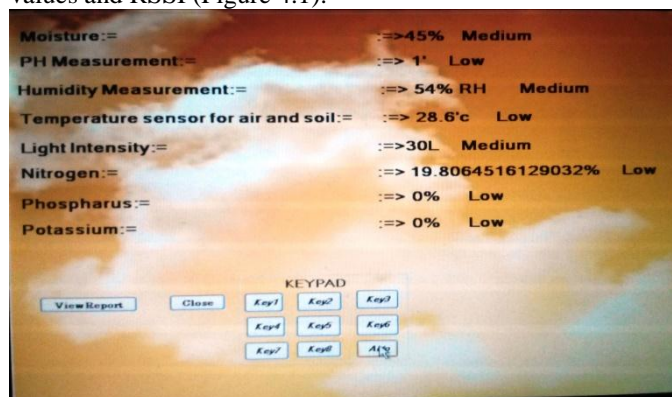

Figure 4.1.VB File output window

This current configuration creates relatively small file sizes with 7500 sets of readings logged in an approximately 520KB file size. The MAC address is logged along with the IP address, as data can be sent unsolicited and the uniqueness of the MAC address provides a way to identify the sender. This is particularly useful in the current situation as DHCP is used and the IP address is initially unknown for modules, or can change over time.

C: DATA EXPORTING TO ACCESS: The CSV file also allows for straightforward exporting into Microsoft Access Depending on the data exported, queried and calculations performed in Microsoft Access, graphs can be created and averaged over various periods based upon TIMESTAMP

V. ADVANTAGES

- 1) It is reliable & self configurable.
- 2) It supports large number of node
- 3) are relatively simple to design and install
- 4) This is very useful to all climatic conditions any it is economic friendly
- 5) This makes increase in productivity and reduces water consumption
- 6) This is safest and no manpower is required.

VI. Application

- 1) For Agricultural management .
- 2) Useful for Green-house management .
- 3) For Industrial environment control.
- 4) Useful for Fertilizer industry to decide the proper content of elements.

- 5) It is also useful at research level for agricultural institutes.

VII. VII. CONCLUSIONS

This system performs well for transferring and logging of values from the various sensor nodes. It allows for relatively easy connection to nodes and communication. Further work is required on protective casing of nodes under extreme weather conditions. The system allows for additional or interchangeable sensors to be connected as the need occurs. This is of special interest due to health concerns connected with nitrates, such as Methemoglobinemia. There is also opportunity to merge the logging and graphing applications, so that there would be minimal user intervention. The system allows for relatively easy use and can be operated with standard commercial products that are commonly implemented allowing users to utilize equipment already in use.

REFERENCES

- [1] I. F. Akyildiz, W. Su, Y. Sankarasubramaniam, and E. Cayirci, "A Survey on Sensor Networks," *IEEE Communications Magazine*, Vol. 40, No.9, pp. 102-114, August 2002.
- [2] I. A. Aziz, M. H. Hasan, M. J. Ismail, M. Mehat, and N. S. Haron, "Remote monitoring in agricultural greenhouse using wireless sensor and short message service (SMS)," *International Journal of Engineering & Technology IJET* Vol: 9 No: 9
- [3] A. D, S. Roy, and S. Bandyopadhyay, "Agro-sense: precision agriculture using sensor-based wireless mesh networks," *First ITU-T Kaleidoscope Academic Conference*.
- [4] J. S. Lin, and C. Liu, "A monitoring system based on wireless sensor network and an SoC platform in precision agriculture," *11th IEEE International Conference on Communication Technology Proceedings*, 2008
- [5] G. W. Irwin, J Colandairaj, and W. G. Scanlon, "An overview of wireless networks in control and monitoring," *International Conference on Intelligent Computing, Kunming , CHINE (2006)*, Vol. 4114, 2006, pp. 1061-1072.
- [6] R.F.M. Inc., "Wireless temperature sensor, application note AN80201, 2009," <http://www.RFM.com/>.
- [7] T. Chi, M. Chen, and Q. Gao, "Implementation and study of a greenhouse environment surveillance system based on wireless sensor network," *The 2008 International Conference on Embedded Software and Systems Symposia (ICESS2008)*
- [8] O. Books, *All about Greenhouses*, LASTOrtho, Meredith Books, 2001, pp. 60-70
- [9] M. Hawfke, S. C. Mukhopadhyay, and H. Ewald, "A zigbee based smart sensing platform for monitoring environmental parameters," *IEEE Instrumentation and Measurement Technology Conference (I2MTC)*, 2011
- [10] F J Veihmeyer, and A H Hendrickson, "Soil Moisture in Relation to Plant Growth," *Annual Review of Plant Physiology*, Vol. 1, 1950, pp. 285-304,
- [11] R.F.M. Inc., "WSN802G series 802.11g wireless sensor network modules integration guide, 2010," <http://www.RFM.com/>.
- [12] M. A. M. Yunus, G. R. Mendez, and S. C. Mukhopadhyay, "Development of a Low Cost System for Nitrate and Contamination Detections in Natural Water Supply based on a Planar Electromagnetic Sensor," *Proceedings of IEEE I2MTC 2011 conference*, IEEE Catalog number CFP11MT-CDR, ISBN 978-1-4244-7934-4, May 10-12, 2011, Hangzhou China, pp. 1557-1562.
- [13] Aline Baggio, "Wireless sensor networks in precision agriculture", <http://www.sics.se/realwsn05/papers/baggio05wireless.pdf>, 2007.